

# AMP CONDENSING BOILERS - SUBMITTAL DATA SHEET

RATINGS AND CAPACITIES		
Input - Low Fire .....	700,000	BTU/HR
Input - High Fire .....	3,500,000	BTU/HR
Output - High Fire .....	3,395,000	BTU/HR
Boiler Horsepower .....	101.4	BHP
Thermal Efficiency .....	97.0%	
Low Fire Thermal Efficiency .....	Up to 99%	
Heating Surface .....	403	Sq.Ft.
Water Content .....	45.3	Gallons
Fuel .....	Natural Gas / Propane	
Firing Rate .....	Full Modulation	
Burner Turndown .....	5:1	
Low NOx Emissions .....	< 10 ppm	
Inlet Gas Pressure (NG) .....	4" wc	Min.
Inlet Gas Pressure (Propane) .....	8" wc	Min.
	14" wc	Max.
Shipping Weight, Approximate .....	2,485	lbs

ASME Section IV (Max 160 PSIG / 21C)
ETL Certified to ANSI Z21.13 / CSA 4.9
ETL Certified to UL 795 / CSA 3.1

DIMENSIONS / CONNECTIONS		
- Height .....	55"	(Note 1)
- Width .....	46"	(Note 2)
- Length .....	97-1/8"	(Note 3)
- Supply Connection .....	4" Grooved	
- Return Connection .....	4" Grooved	
- Vent / Air Intake Connections .....	12"	
- Gas Connection .....	2" NPT	

STANDARD EQUIPMENT	
- ASME Stainless Steel Heat Exchanger	
- Stainless Steel Pre-Mix Burner	
- Variable Speed Combustion Blower	
- Concert Control™ (24v)	
- High Limit Temperature Control, Manual Reset	
- Water Flow Switch	
- Low Water Cutoff, Manual Reset	
- Condensate Trap	
- Blocked Condensate Switch	
- ASME Pressure Relief Valve	
- Pressure / Temperature Gauge	
- Supply & Return Temperature Sensors	
- Flue Gas Temperature Sensor	
- Manual Fuel Changeover Switch	
- Modulating Gas Valve	
- Direct Spark Ignition and UV Scanner	
- High/Low Gas Pressure Switches, Manual Reset	
- Combustion Air Switch	
- Blocked Vent Switch	
- 208-240-460v/3ph/60hz Line Voltage	
- Amp Draw: 208v (11.0); 240v (9.9) and 460v (6.4)	
- Category II and IV Venting	
- Individual or Common (Engineered) Vent System	
- CPVC, Polypropylene & Stainless Steel Acceptable *Material	
- Sealed or Room Combustion Air Intake	
- Up to 300 ft equivalent venting / air intake	

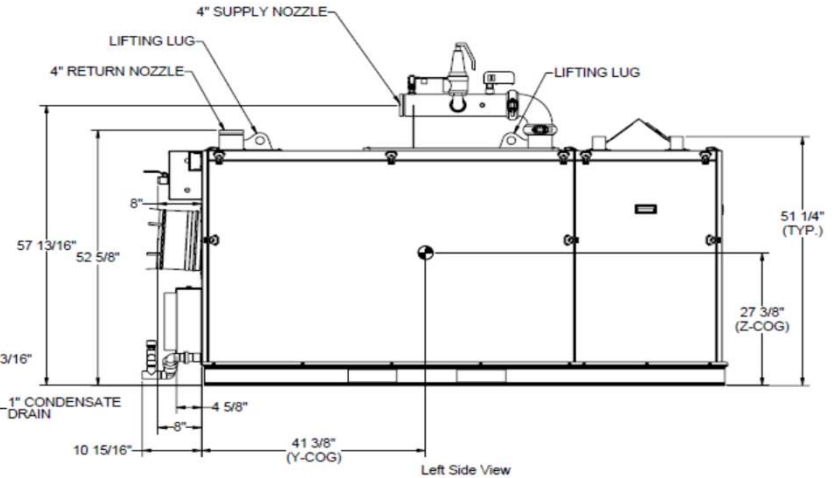
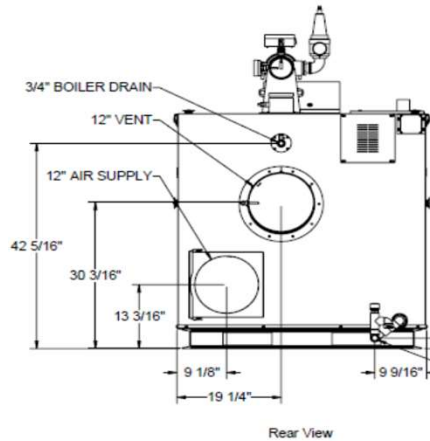
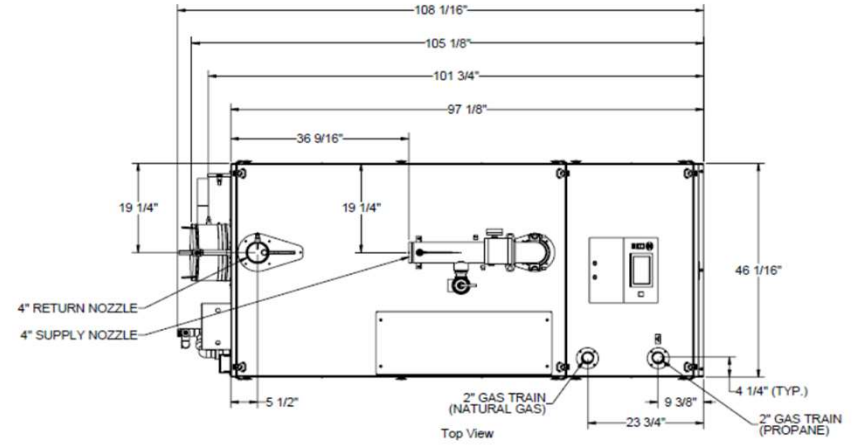
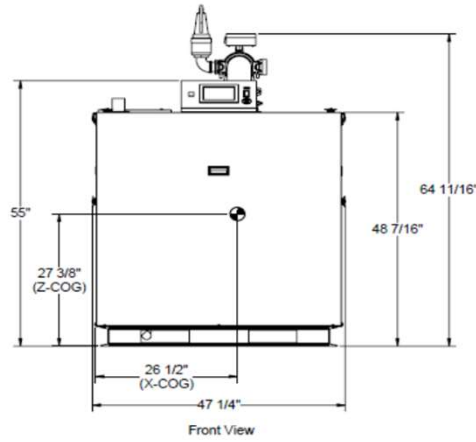

- NOTES:
1. Height dimension is from floor to top of control box.
  2. Width does not include jacket butterfly clips that require 3/4" +/- clearance on each side.
  3. Length is the measurement of the boiler skid base.
  4. Dimensions shown are for reference only

FLOWS AND PRESSURE DROPS		
Delta T	Flow (GPM)	r P (Ft. Hd)
20°F r T (Max)	340	15.5
25°F r T	272	10.6
30°F r T	226	8.1
35°F r T	194	6.5
40°F r T	170	5.3
45°F r T	151	4.4
50°F r T	136	3.7
55°F r T (Min)	123	3.5

\* Flue system material shall be capable of continuous operation at 210°F or higher and shall be certified to UL 1738 – venting system for gas-burning appliances cat II, III and IV.

## AMP-3500-DF

PROPERTY OF  
**THERMAL SOLUTIONS**  
Manufactured Equipment for the Water Industry

PO BOX 3244 | LANCASTER, PA 17601

INNOVATIVE EQUIPMENT FOR  
HOT WATER SYSTEMS

WWW.THERMALSOLUTIONS.COM

Updated 1/26/2024